

**HDST**<sup>®</sup>

## **HD-RGL** 双溢流高温高速染色机

HD-RGL Overflow High Temperature High speed Dyeing Machine



品质、服务、创新是华迪人永恒的追求  
Huadi always keep the high quality, good servie and innvoation.

盐城市华迪机械制造有限公司

地址：江苏省射阳县经济开发区人民东路  
电话：0515-82319933 传真：0515-82309159  
电子信箱：ychd2319933@163.com  
公司网址：www.cnhdst.com

**YANCHENG HUADI MACHINERY MANUFACTURING CO., LTD**

Address: Renmin East Road, Economic Development Zone,  
Sheyang County, Jiangsu Province, China  
Tel: 0515-82319933 Fax: 0515-82309159  
E-mail: ychd2319933@163.com  
Website: http://www.cnhdst.com

由于产品不断改进设计，所提供的产品与样本中所描述的有所不同，本公司拥有对产品本解释权

**盐城市华迪机械制造有限公司**  
YANCHENG HUADI MACHINERY MANUFACTURING CO., LTD



# HD-RGL 双溢流高温高速染色机

HD-RGL Overflow High Temperature High speed Dyeing Machine



## 应用领域:

- ★ 本机多项专利设计，从一般的针织布到最新发展的弹性布料，均可使用，如全棉弹性布、螺纹粘胶弹性布、聚酯涤纶弹性布、尼龙锦纶弹性布等；
- ★ 溢流与喷射水流可供选择，克重从50-600g/m<sup>2</sup>
- ★ 复合变径式导布管：可将张力降至最小并且有效消除经向折痕的动能；
- ★ 布槽短，布长适中，浴比低，操作保养简单；
- ★ 机台高度低，张力低、染色后缩率小，成品克重容易达成；
- ★ 筒身采用316L高度抗腐蚀A级不锈钢；
- ★ 高强度耐高压筒身及热交换器。

## Application field:

- ★ HD-RGL with many patent designs, it suitable for the general knitting fabric to the elastic fabric, such as cotton elastic fabric, thread viscose elastic fabric, polyester elastic fabric, nylon elastic fabric, etc.
- ★ Overflow or jet flow are available, the suitable weight is from 50 to 600g/m<sup>2</sup>.
- ★ Composite variable diameter type fabric guide tube: the tension can be minimized and effectively eliminate the function of warp crease.
- ★ The cloth groove is lower, the fabric length is moderate, the liquor ratio lower, operation and maintenance are simply.
- ★ The height of the machine is low, the tension is low, the shrinkage rate after dyeing is small, and the weight of the finished product is easy to achieve.
- ★ The machine body is made 316L highly corrosion-resistant grade A stainless steel.
- ★ High strength & high pressure main body and heat exchanger.



品质 · 服务 · 创新 high quality, good service and innovation.

## HD-RGL

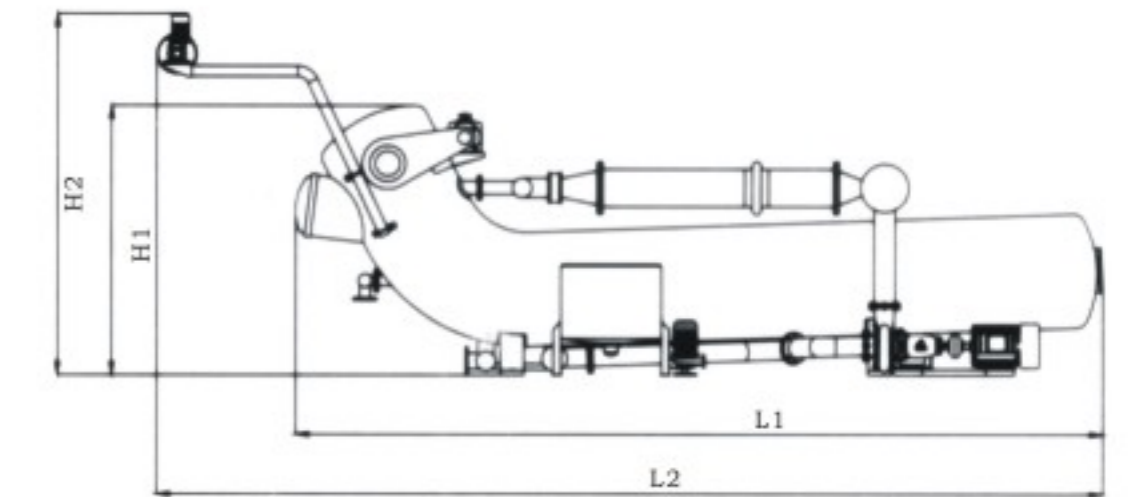
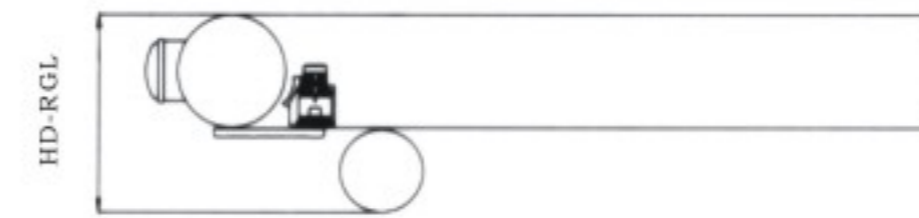

## 规格 Specifications/

项目 Item	型号 Model	HD-RGL100	HD-RGL250	HD-RGL500	HD-RGL1000	
管数 / 槽数 Number of tubes / chambers		1/2	1/2	2/4	4/8	
容量 (最大) Max. Capacity	公斤 Kg	70-100	175-250	350-500	700-1000	
	磅 Lb	155-220	385-550	220-1100	1545-2200	
浴比 Liquor ratio		1:6-8				
最高工作温度(°C) Max. working temperature		140°C				
速度 Speed (RPM)	喷射 Jetflow	0-450				
	溢流 Overflow	0-250				
升温速度 (20°C) 分 Heating rate (Min)		35				
降温速度 (140°C) 分 Cooling rate (Min)		30				
使用马达总功率 (KW) Total motor power		15	19.5	37.5	69.5/88	
机械尺寸 Machine dimension (mm)	长 Length	L1	4700	6990	6990	6990
		L2	5800	8090	8090	8090
	宽 Width		1700	1700	3100	6050
		高 Height	H1	2300	2300	2300
H2	3080		3080	3080	3180	

● 列所列规格如有改良或修正，不再另行通知。 No further notice shall be given if the specifications listed are modified or amended.

## HD-MRGL

“精品机 Sample dyeing machine”

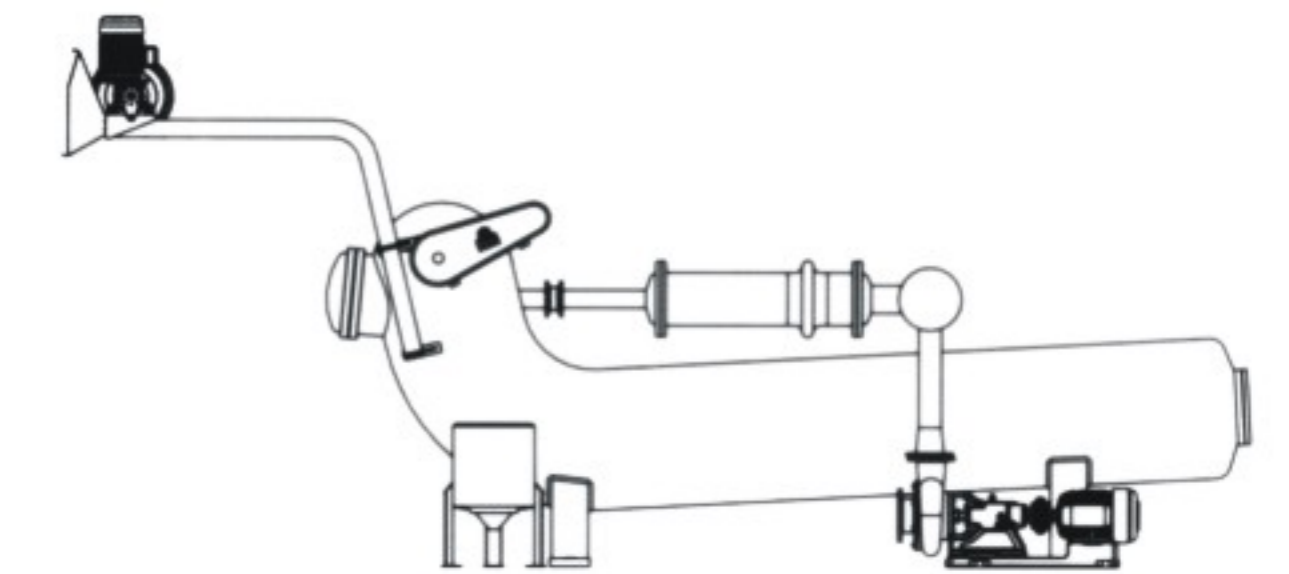

## 规格 Specifications/

项目 Item	型号 Model	HD-MRGL25	HD-MRGL50	HD-MRGL75	
管数 / 槽数 Number of tubes / chambers		1/1	1/1	1/1	
容量 (最大) Max. Capacity	公斤 Kg	18-25	35-50	50-75	
	磅 Lb	40-55	75-110	110-165	
浴比 Liquor ratio		1:6-8			
最高工作温度(°C) Max. working temperature		140°C			
速度 Speed (RPM)	喷射 Jetflow	0-350			
	溢流 Overflow	0-200			
升温速度 (20°C) 分 Heating rate (Min)		25			
降温速度 (140°C) 分 Cooling rate (Min)		20			
使用马达总功率 (KW) Total motor power		8.5	10.5	10.5	
机械尺寸 Machine dimension (mm)	长 Length	L1	3810	4900	5400
		L2	5240	6350	6830
	宽 Width		1450	1450	1530
		高 Height	H1	1910	1910
H2	2730		2730	2730	

● 列所列规格如有改良或修正，不再另行通知。 No further notice shall be given if the specifications listed are modified or amended.